

# Real-Time Electrochemical Monitoring: Toward Green Analytical Chemistry

JOSEPH WANG

Department of Chemistry, New Mexico State University,  
Las Cruces, New Mexico 88003

Received September 12, 2001

## ABSTRACT

This Account presents a survey of recent advances in electrochemical sensing technology relevant to green analytical chemistry and examines the potential advantages, limitations, and applications of these monitoring devices. Stricter environmental control and effective process monitoring have created considerable demands for innovative analytical methodologies. New devices and protocols, with negligible waste generation or no hazardous substances, and in situ real-time monitoring capability are particularly needed for addressing the challenges of green analytical chemistry. The coupling of modern electrochemical detection principles with recent advances in molecular recognition, microelectronics, and microfabrication has led to powerful, compact, and “user-friendly” analytical devices. The unique features of such electrochemical monitoring systems make them particularly attractive for addressing environmental and industrial problems and the challenges of green chemistry. These developments allow the instrument to be taken to the sample (rather than the traditional way of bringing the sample to the laboratory) and hence to ensure effective process or pollution control.

## Introduction

A major thrust of the green chemistry research activity is the development of new analytical methodologies.<sup>1</sup> For example, new analytical tools are needed for real-time industrial process monitoring and for preventing the formation of toxic materials.<sup>1</sup> The growing field of process analytical chemistry is aimed primarily at obtaining the analytical data close to the production operation.<sup>2</sup> Such capability offers improved process control while minimizing its environmental impact. Similarly, a real-time field measurement capability is desired for continuous environmental monitoring that would replace the common approach of sample collection and transport to a central laboratory.<sup>3</sup> Such monitoring offers a rapid return of the chemical information (with a proper alarm in case of a sudden discharge), while minimizing errors and costs associated with laboratory-based analyses. The develop-

ment of “greener” analytical protocols and devices, with negligible waste generation or nontoxic materials, is of considerable interest, in connection to both centralized and decentralized (field) analyses. These green chemistry principles should thus be applied to all aspects of the analytical science.

This Account highlights recent advances, primarily from the author’s laboratory, aimed at developing electrochemical systems for meeting the needs of green analytical chemistry. Electrochemical devices offer unique opportunities for addressing the challenges of green analytical chemistry, namely providing effective process monitoring while minimizing its environmental impact. The advantages of electrochemical systems include high sensitivity and selectivity, a wide linear range, minimal space and power requirements, and low-cost instrumentation. Devices based on potentiometry (e.g., pH), conductivity, and amperometry (e.g., oxygen) have all been used for many years.<sup>4</sup> The past two decades have seen enormous advances in electroanalytical chemistry, including the development of ultramicroelectrodes, the design of tailored interfaces, the coupling of biological components with electrical transducers, the microfabrication of molecular devices, and the introduction of “smart” sensors and sensor arrays. Advances in controlled-potential techniques have greatly increased the ratio between the analytical and background currents to allow quantitation down to the parts per trillion range.<sup>4</sup> Similarly, recent developments in polymer membrane ion-selective electrodes have “pushed” the detection limits of these potentiometric devices to a similar level.<sup>5</sup> The coupling of modern electrochemical detection principles with recent advances in microelectronics and microfabrication has led to powerful and compact analytical devices for real-time, in process-monitoring. These developments have led to a substantial increase in the popularity of electroanalysis, and to its expansion into new phases and environments.

As we enter the 21st century, we no longer rely on cumbersome electrochemical cells and bulky electrodes, but rather on fast, small, easy-to-use, “smart” and “environmentally friendly” electrochemical systems. A vast array of devices for on-site and in situ environmental and industrial monitoring has been developed in recent years.<sup>3,6</sup> Several representative examples, illustrating the scope, power, and versatility of such miniaturized and powerful electrochemical devices and systems, are described in the following sections. The readers are referred to several books for a comprehensive information on electrochemical systems.<sup>4</sup>

## Toward Green and Easy-To-Use Electrodes

The elimination of hazardous materials from the analytical protocol is a major thrust of green analytical chemistry. The performance of electrochemical measurements is strongly influenced by the material of the working electrode.<sup>4</sup> For many years, mercury was the choice of electrode material due to its very attractive behavior and

Joseph Wang is currently a Manasse Chair and a Regent Professor of Chemistry at New Mexico State University. He obtained his higher education at the Israel Institute of Technology, being awarded his D.Sc. in 1978. From 1978 to 1980, he served as a research associate at the University of Wisconsin (Madison). His research interests include the development of electrochemical sensing devices for clinical and environmental monitoring, microfabrication and miniaturization, DNA recognition and diagnostics, biochips, and microfluidic (“lab-on-chip”) devices. Professor Wang is the recipient of the 1994 Heyrovsky Memorial Medal (of the Czech Republic) for his contributions to voltammetry, and of the 1999 American Chemical Society Award for Analytical Instrumentation. He is currently serving as the Chief Editor of the international journal *Electroanalysis* and as a member of the editorial board of 10 additional international journals.

highly reproducible, renewable, and smooth surface. These unique properties of mercury drop electrodes led to the 1958 Nobel Prize in Chemistry. Both the dropping and hanging drop electrodes have been widely used in connection to various polarographic and voltammetric techniques. Routine applications of these mercury-based procedures can result in the daily generation of a few grams of mercury waste. However, because of the toxicity of mercury, alternative (greener) electrode materials are highly desired for both centralized and field applications.

Various non-mercury electrodes have thus been examined. In particular, we demonstrated recently that bismuth-film electrodes offer high-quality trace-metal measurements that compares favorably with those of mercury electrodes.<sup>7</sup> Bismuth is a "green" element, with very low toxicity and widespread pharmaceutical use. "Environmentally friendly" carbon electrodes have been widely used in electroanalysis for more than three decades due to their low background current, wide potential window, chemical inertness, low cost, and suitability for various sensing and detection applications. The analytical power and scope of carbon (and other solid) electrodes can be greatly enhanced through a deliberate modification of their surface.<sup>8</sup> The resulting chemically modified electrodes can benefit monitoring applications through a preferential accumulation of target contaminants, the exclusion of unwanted materials (e.g., surface-active macromolecules), or acceleration of desired electron-transfer reactions. The miniaturization of solid electrode offers several fundamental and practical advantages,<sup>9</sup> including a dramatic reduction in the sample consumption. The significant reduction of resistance (ohmic drop) effects at these tiny electrodes greatly facilitates voltammetric measurements in low-ionic-strength water samples.

To address the needs of decentralized (field) testing, it is necessary to move away from cumbersome electrodes and cells (commonly used in research laboratories). The exploitation of advanced microfabrication techniques allows the replacement of traditional ("beaker-type") electrochemical cells and bulky electrodes with easy-to-use sensor strips. Both thick-film (screen-printing) and thin-film (lithographic) fabrication processes have thus been used for high-volume production of highly reproducible, effective, and inexpensive sensors strips. Such strips rely on planar working and reference electrodes on a plastic or silicon substrate (Figure 1). These strips can thus be considered as self-contained electrochemical cells onto which the sample droplet is placed. The thin-film fabrication route facilitates also the development of cross-reactive electrode arrays<sup>10</sup> that are useful for multiparameter process or pollution control (in connection to advanced signal-processing algorithms).

## Real-Time Electrochemical Monitoring

In process control and environmental monitoring, samples are traditionally collected and transported to a central laboratory for the subsequent determination of the chemical composition. The use of sensors and detectors to

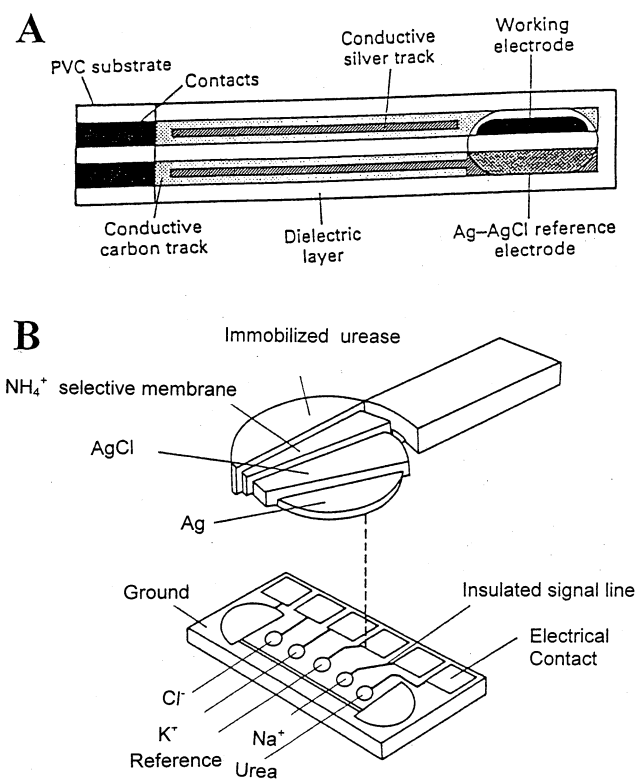

**FIGURE 1.** Modern microfabricated self-contained planar electrochemical cells on a plastic (A) or silicon (B) substrate. (Courtesy of Medisense and i-Stat Corps., respectively.)

continuously measure important chemical properties has significant technical and cost benefits over this traditional sampling and analysis. By providing a fast return of the analytical information in a timely, safe, and cost-effective fashion, such devices offer direct and reliable assessment of the production progress or the fate and gradient of contaminants sites, while greatly reducing the huge analytical costs. Such real-time monitoring capability can be accomplished through on-line or submersible operations. Despite major advances,<sup>3,6</sup> there are still many challenges related to the achievement of highly stable and reliable monitoring. These include the long-term stability (of both the recognition and transduction elements), related baseline drift, matrix effects, reversibility, and in situ calibration.

**Real-Time Monitoring of Toxic Metals.** Atomic spectroscopic techniques, commonly used for measuring trace metals in the central laboratory, are not suitable for the task of on-site analyses. Electrochemical stripping analysis has always been recognized as a powerful tool for measuring trace metals.<sup>11</sup> Its remarkable sensitivity is attributed to the "built-in" preconcentration step, during which the target metals are accumulated onto the working electrode. The portable instrumentation and low power demands of stripping analysis satisfy many of the requirements for on-site and in situ measurements of trace metals. Automated stripping flow analyzers have been developed for continuous on-line monitoring of trace metals since the mid-1970s.<sup>12</sup> Remote/submersible probes circumvent the need for solution pumping and offer greater simplification and miniaturization. Such remote

metal monitoring has been realized by eliminating the needs for mercury electrodes, oxygen removal, forced convection, or supporting electrolyte (which previously prevented the direct immersion of stripping electrodes into sample streams).<sup>13</sup> The in situ monitoring capability of the remote metal sensor was demonstrated in studies of the distribution of trace copper in San Diego Bay.<sup>14</sup> Buffle's group has also made pioneering contributions to in situ measurements of trace metals<sup>15</sup> and recently described a submersible and robust voltammetric in situ profiling (VIP) system (based on advanced microprocessor and telemetry technology)<sup>16</sup> and a novel voltammetric microelectrode array for real-time monitoring of the fluxes of metals across the sediment–water interface (in connection to an effective protective agar coating).<sup>17</sup> Such surface protection is crucial for achieving the system robustness (essential for a long-term in situ monitoring) in the presence of coexisting surface-active constituents. Metal speciation studies in non-saline inland water can greatly benefit from the minimization of resistance effect at ultramicroelectrodes (that obviates the need for an external electrolyte).<sup>18</sup>

**Electrochemical Biosensors for Continuous Monitoring.** Biosensors—coupling highly specific biological recognition elements with electrical transducers—continue to attract considerable attention in the scientific community. The environmental and industrial interest in biosensor technology has been driven by the needs for faster, simpler, cheaper, and better monitoring tools.<sup>19</sup> The remarkable selectivity of the biological recognition event allows direct measurements of target analytes in untreated real samples. Electrochemical biosensors hold a leading position among the bioprobes currently available and hold great promise for the task of environmental and industrial monitoring. A great variety of schemes for implementing the electrochemical biosensing route, based on different combinations of biocomponents and electrode transducers, have been suggested. These rely on the immobilization of enzymes, antibodies, nucleic acids, or whole cells onto amperometric or potentiometric electrode transducers. These transducers convert the biological recognition process into a useful current or potential signal (Figure 2). Fundamental aspects of these devices have been reviewed.<sup>4</sup>

The integration of electrochemical biosensors with the remotely deployed probes adds new dimensions of specificity into in situ monitoring of pollutants.<sup>5</sup> In the adaptation of enzyme electrodes to a submersible operation, one must consider the influence of actual field conditions (pH, salinity, temperature) upon the biocatalytic activity. The lack of long-term enzymatic stability can also limit the prolonged operation of such biocatalytic probes. The first remotely deployed biosensor targeted phenolic contaminants in connection to a submersible tyrosinase enzyme electrode.<sup>20</sup> The enzyme, immobilized within a carbon paste matrix, converted its phenolic substrates to easily reducible (detectable) quinone products. The sensor responded rapidly to micromolar levels of various phenol pollutants, with no carryover (memory) effects. Analogous

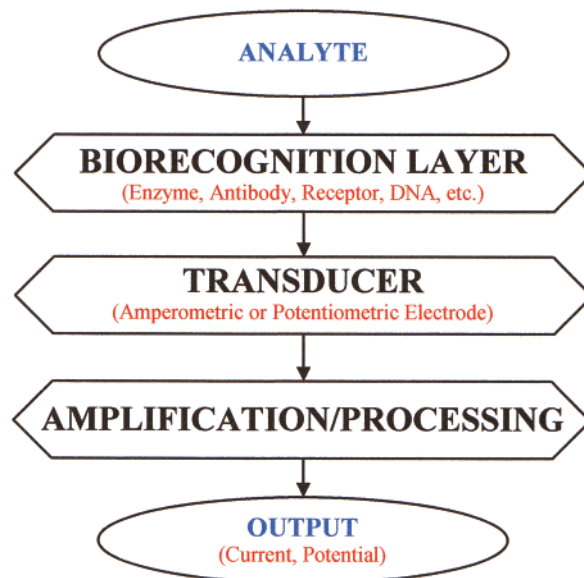

FIGURE 2. Electrochemical biosensors: intimate coupling of specific biorecognition events and an electrical signal transduction.

remote measurements of organophosphorous pesticides (e.g., paraoxon, parathion), based on immobilized organophosphorous hydrolase (OPH), were reported.<sup>21</sup>

Electrochemical biosensors have also been developed for monitoring organic streams and harsh environments common in industrial process control.<sup>22</sup> In particular, organic-phase flow detectors could lead to a wide range of previously inaccessible industrial processes. On-line assays of alcohols in petrochemical samples or flow injection measurements of trace water in organic media have already been demonstrated.<sup>22</sup>

**Lab-on-Cable.** Our recent activity has led to the development of submersible electrochemical analyzers.<sup>23</sup> As opposed to in situ sensors (that lack the sample preparatory steps essential for an optimal analytical performance), the new “lab-on-cable” incorporates several functions into a single sealed, submersible package. The first generation of this submersible microanalyzer integrates the in situ microdialysis sampling with reservoirs for the reagent, waste, and calibration/standard solution, along with the micropump and necessary fluidic network on a cable platform (Figure 3). The sample and reagent are thus brought together, mixed, and allowed to react in a reproducible manner. The internal buffer solution ensures independence of sample conditions such as pH or ionic strength. On-cable metal complexation reactions or enzyme-inhibition ones have thus been demonstrated in connection measurements of trace chromium<sup>24</sup> or cyanide,<sup>25</sup> respectively. Other groups have developed submersible reagent-based flow spectroscopic analyzers for long-term oceanographic monitoring<sup>26</sup> or process control.<sup>27</sup>

**Lab-on-a-Chip.** Microfabricated microfluidic analytical devices, integrating multiple sample-handling processes with the actual measurement step on a microchip platform (Figure 4), are of considerable recent interest.<sup>28,29</sup> For obvious reasons, such devices are referred to as “lab-on-

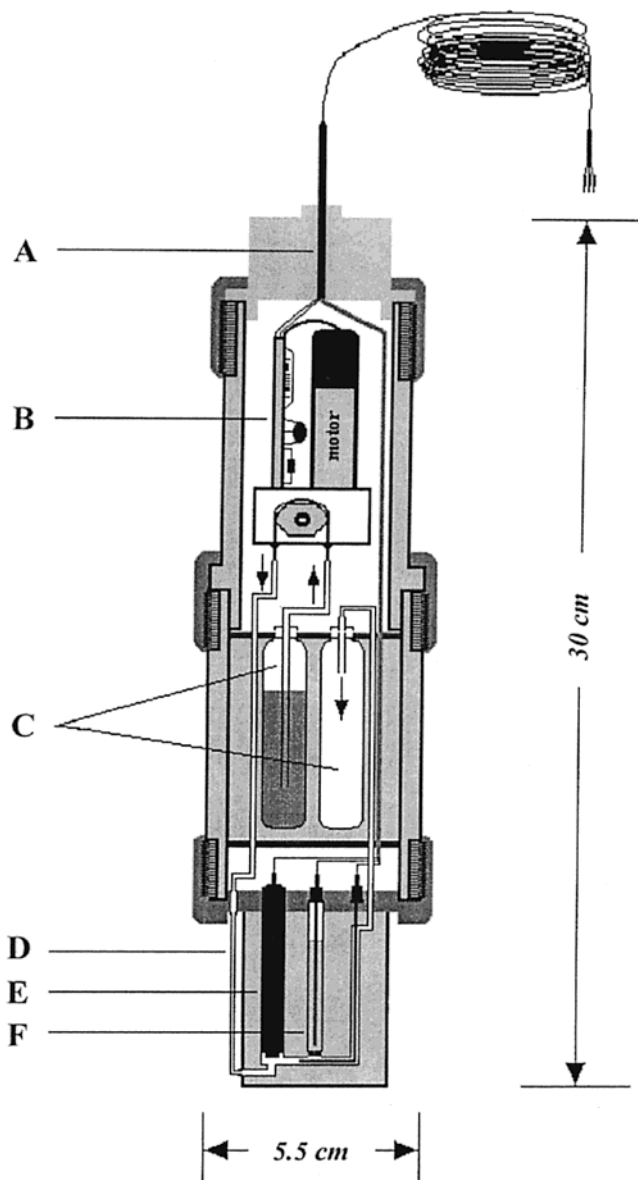

**FIGURE 3.** Schematic diagram of the electrochemical "lab-on-cable" system. (A) Cable connection; (B) micropump; (C) reservoirs for reagent and waste solutions; (D) microdialysis sampling tube; (E,F) electrochemical flow detector, with working and reference electrodes, respectively. Reproduced with permission from ref 23. Copyright 2000 American Chemical Society.

a-chip" devices. Complete assays, involving sample pretreatment (e.g., preconcentration/extraction), chemical/biochemical derivatization reactions, electrophoretic separations, and detection, have thus been realized on single microchip platforms. Such analytical microsystems rely on electrokinetic fluid "pumping" and obviate the needs for pumps or valves. Highly effective separations combined with short assay times have been achieved by combining long separation channels and high electric fields. The enhanced performance and advantages of microfluidic devices relative to conventional (benchtop) analytical systems have been demonstrated through theory and experiment.<sup>30</sup>

The dramatic downscaling and integration of chemical assays make these analytical microsystems particularly

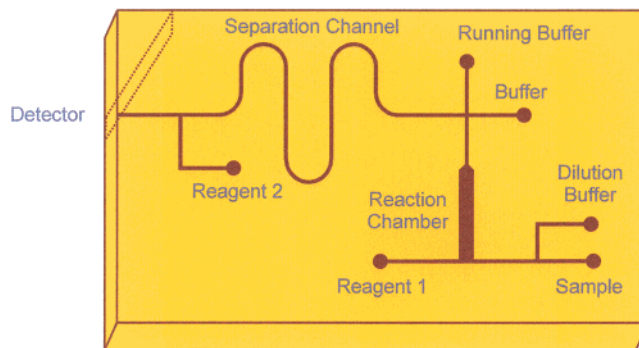
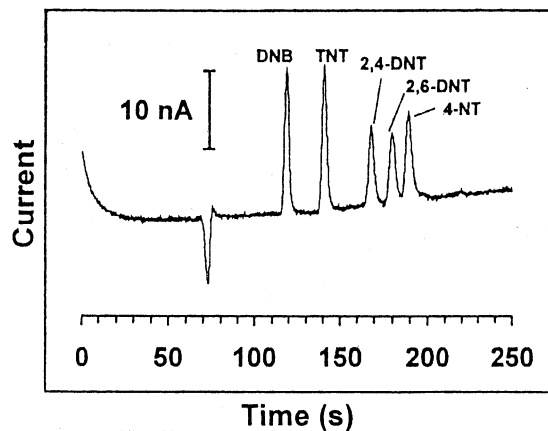

**FIGURE 4.** Lab-on-a-chip: Integration of multiple functional elements—relevant to various sample preparation and measurements steps—onto a microchip platform.

attractive as "green analytical chemistry" screening tools and hold considerable promise for faster and simpler on-site monitoring of priority pollutants. Particularly attractive for on-site environmental or industrial applications are the small dimensions/portability, minimal solvent/reagent consumption and waste production (to the nanoliter level), high degree of integration, efficiency, speed, and disposability. The amount of waste generated is reduced by ca. 4–5 orders of magnitude, in comparison, for example, to conventional liquid chromatographic assays (e.g., 10  $\mu\text{L}$  vs 1 L per daily use). Such significant improvement in the rate of waste generation and material consumption has enormous implications to green chemistry. The high degree of integration offered by "lab-on-a-chip" devices implies that the principles of green chemistry can be applied to all the steps of the analytical process. A recent contribution from Harrison's team<sup>31</sup> demonstrated a convenient interface of microfluidic devices to the external environment. Such ability to continuously introduce real samples into micrometer channels would make "lab-on-a-chip" devices compatible with real-life monitoring applications.

Electrochemistry offers great promise for such microsystems, with features that include high sensitivity (approaching that of fluorescence), inherent miniaturization and integration of both the detector and control (potentiostatic) instrumentation, independence of optical path length or sample turbidity, low power requirements, low cost, and high compatibility with advanced microfabrication and micromachining technologies.<sup>32,33</sup> Such properties make electrochemical detection extremely attractive for creating truly portable (and possibly disposable) stand-alone microsystems. Optical detection systems, in contrast, are still relatively large, hence compromising the benefits of miniaturization. Various detector configurations, based on different capillary/working electrode arrangements and the position of the electrode relative to the flow direction, have been employed in connection to electrochemical detection.<sup>32,33</sup> The characteristic common of most of these is the placement of the detector outside the separation channel, which results in effective isolation from the high separation potential.

A great number of environmental applications of CE/EC microchips have already appeared, including rapid



**FIGURE 5.** Electropherogram for a mixture of nitroaromatic explosives: 10 mg/L DNB, 2,4-DNT, 2,6-DNT, and TNT, and 20 mg/L 4-NT. Thick-film amperometric carbon detector held at  $-0.7$  V; run borate buffer (15 mM, pH 8.7) containing 25 mM SDS. Reproduced with permission from ref 34. Copyright 1999 American Chemical Society.

separation and detection of chlorophenols, nitroaromatic explosives, hydrazines, or organophosphate pesticides.<sup>32,33</sup> For example, Figure 5 displays a typical electropherogram for a sample mixture containing micromolar concentrations of five nitroaromatic explosives. The power and scope of electrochemical microsystems have been further enhanced through the coupling of on-chip enzymatic or immunochemical reactions.<sup>35</sup> The small footprint of microchip devices permits the adaptation of highly parallel assays (in multichannel manifolds), including the various sample manipulations and pretreatment functions. Parallel assays of various classes of contaminants could thus be realized. Credit-card-sized analyzers and single-use microlaboratories (based on mass-produced plastic chips and integrated electrochemical detection), suitable for a wide range of environmental and industrial applications, can thus be envisioned.

## Concluding Remarks and Future Prospects

The green chemistry revolution provides new challenges and exciting opportunities for electroanalytical chemistry, and for developing greener analyses, in general. The examples described in this Account illustrate the power and versatility of modern electrochemical systems and the potential for minimizing hazardous substances and waste generation during electrochemical assays. The combination of modern electrochemical techniques with breakthroughs in microelectronics and miniaturization allows the introduction of powerful analytical devices for effective process or pollution control. Such real-time on-site monitoring technologies successfully address the time constraints associated with classical laboratory analysis. Like personal computers, electrochemical devices have become more sophisticated and versatile while dramatically shrunk in size and weight. The new generation of electrochemical analyzers offers tremendous potential for obtaining the desired analytical information in a faster, simpler, and cheaper manner compared to traditional laboratory-based

instruments. The consequence of these developments is that major considerations are now given to on-site and real-time electrochemical measurements. Such measurements should have a major impact upon the monitoring of priority pollutants and industrial processes. The practical realization of these monitoring scenarios requires proper attention to the robustness of these systems and devices. It should be pointed out, also, that electrochemical devices are still limited in scope and cannot address all environmental or industrial monitoring needs. Ongoing commercialization efforts, coupled with regulatory acceptance (along with acceptance by plant and environmental engineers), should lead to the translation of the above research activity into large-scale environmental and industrial applications. Such new electrochemical systems hold great promise for meeting the needs and challenges of "green analytical chemistry" in the 21st century.

*The author thanks the co-workers and collaborators who have contributed to the research on electrochemical sensors, detectors, and microsystems. This work was supported by grants from the EPA, DOE, ONR, and NASA.*

## References

- (1) (a) Anastas, P. T. Green Chemistry and the Role of Analytical Methodology Development. *Crit. Rev. Anal. Chem.* **1999**, *29*, 167–175. (b) Anastas, P. T.; Warner, J. C. *Green Chemistry: Theory and Practice*; Oxford University Press: New York, 1998.
- (2) Workman, J.; Creasy, K. E.; Doherty, S.; Bond, L.; Koch, M.; Ullman, A.; Veltkamp, D. Process Analytical Chemistry. *Anal. Chem.* **2001**, *73*, 2705.
- (3) Buffle, J.; Horvai, G., Eds. *In Situ Monitoring of Aquatic Systems: Chemical Analysis and Speciation*; Wiley: New York, 2001.
- (4) (a) Wang, J. *Analytical Electrochemistry*, 2nd ed.; Wiley: New York, 2000. (b) Brett, C. M.; Brett, A. M. O. *Electrochemistry: Principles, Methods and Applications*; Oxford University Press: Oxford, 1993.
- (5) Bakker, E.; Buhlmann, P.; Prestsch, E. Polymer Membrane Ion-Selective Electrodes—What are the limits? *Electroanalysis* **1999**, *11*, 915–933.
- (6) Wang, J. Remote Electrochemical Sensors for Monitoring Inorganic and Organic Pollutants. *Trends Anal. Chem.* **1997**, *16*, 84–88.
- (7) Wang, J.; Lu, J.; Hocevar, S.; Farias, P.; Ogorevc, B. Bismuth-Coated Carbon Electrodes for Anodic Stripping Voltammetry. *Anal. Chem.* **2000**, *72*, 3218–3222.
- (8) Murray, R. W.; Ewing, A. G.; Durst, R. A. Chemically Modified Electrodes: Molecular Design for Electroanalysis. *Anal. Chem.* **1987**, *59*, 379A–390A.
- (9) Wightman, R. M. Microvoltammetric Electrodes. *Anal. Chem.* **1981**, *53*, 1125A–1134A.
- (10) (a) Diamond, D. Progress in Sensor Array Research. *Electroanalysis* **1993**, *5*, 795–802. (b) Albert, K.; Lewis, N. S.; Schauer, C.; Soltzing, G.; Stitzel, S.; Vaid, T.; Walt, D. R. Cross-Reactive Chemical Sensor Arrays. *Chem. Rev.* **2000**, *100*, 2595–2626.
- (11) Wang, J. *Stripping Analysis*; VCH Publishers: New York, 1985.
- (12) Zirino, A.; Lieberman, S.; Clavell, C. Measurements of Cu and Zn in San Diego Bay by Automated Anodic Stripping Voltammetry. *Environ. Sci. Technol.* **1978**, *12*, 73–79.
- (13) Wang, J.; Larson, D.; Foster, N.; Armalis, S.; Lu, J.; Rongrong, X.; Olsen, K.; Zirino, A. Remote Electrochemical Sensor for Trace Metal Contaminants. *Anal. Chem.* **1995**, *67*, 1481–1485.
- (14) Wang, J.; Foster, N.; Armalis, S.; Larson, D.; Zirino, A.; Olsen, K. Remote Stripping Electrode for in-situ Monitoring of Labile Copper in the Marine Environment. *Anal. Chim. Acta* **1995**, *310*, 223–231.
- (15) Terrier, M. L.; Buffle, J. In-situ Voltammetric Measurements in Natural Waters: Future Prospects and Challenges. *Electroanalysis* **1993**, *5*, 187–200.
- (16) Terrier, M. L.; Buffle, J.; Graziottin, F. A Novel Voltammetric In-situ Profiling System for Continuous Real-time Monitoring of Trace Elements in Natural Water. *Electroanalysis* **1998**, *10*, 355–363.

- (17) Pei, J.; Tercier-Waeber, M. L.; Buffle, J.; Fiaccabrino, G. C.; Koudelka-Hep, M. Individually-Addressable Gel-Integrated Voltammetric Microelectrode Array for High-Resolution Measurements of Concentration Profiles at Interfaces. *Anal. Chem.* **2001**, *73*, 2273–2281.
- (18) Wang, J.; Zadeii, J. ASV at Ultramicroelectrodes for Metal Speciation Studies in Aqueous Solutions of Low Ionic Strength. *J. Electroanal. Chem.* **1988**, *246*, 297–305.
- (19) Rogers, K. R.; Gerlach, C. L. Environmental Biosensors: A Status Report. *Environ. Sci. Technol.* **1996**, *30*, 486A–491A.
- (20) Wang, J.; Chen, Q. Remote Electrochemical Biosensor for Field Monitoring of Phenolic Compounds. *Anal. Chim. Acta* **1995**, *312*, 39–44.
- (21) Wang, J.; Chen, L.; Mulchandani, A.; Mulchandani, P.; Chen, W. Remote Biosensor for in-situ Monitoring of Organophosphorous Nerve Agents. *Electroanalysis* **1999**, *11*, 866–869.
- (22) Wang, J. Organic-Phase Biosensors—New Tools for Flow Analysis: A Short Review. *Talanta* **1993**, *40*, 1905–1909.
- (23) Wang, J.; Lu, J.; Tian, T.; Ly, S.; Vuki, M.; Adeniyi, W.; Armennderiz, R. Lab-on-a-Cable for Electrochemical Monitoring of Phenolic Compounds. *Anal. Chem.* **2000**, *72*, 2659–2663.
- (24) Wang, J.; Wang, J.; Lu, J.; Tian, B.; MacDonald, D.; Olsen, K. Flow Probe for in-situ Electrochemical Monitoring of Trace Chromium. *Analyst* **1999**, *124*, 349–352.
- (25) Wang, J.; Tian, B.; Lu, J.; MacDonald, D.; Wang, J.; Luo, D. Renewable-Reagent Enzyme Inhibition Sensor for Remote Monitoring of Cyanide. *Electroanalysis* **1998**, *10*, 1034–1037.
- (26) Jannasch, H. W.; Johnson, K. S.; Sakamoto, C. M. Submersible Osmotically Pumped Analyzers for Continuous Determination of Nitrate in Situ. *Anal. Chem.* **1994**, *66*, 3352–3361.
- (27) Moore, L.; Veltkamp, D.; Cortina, J.; Lin, Z.; Burgess, L. Miniature Flow Probe Chemical Sensor. *Sens. Actuators B* **1997**, *38*, 130–135.
- (28) Figeys, D.; Pinto, D. Lab-on-a-Chip: A Revolution in Biological and Medical Sciences. *Anal. Chem.* **2000**, *71*, 330A–336A.
- (29) Kutter, J. P. Current Developments in Electrophoretic and Chromatographic Separation Methods on Microfabricated Devices. *Trends Anal. Chem.* **2000**, *19*, 352–359.
- (30) Jakeway, S. C.; de Mello, A. J.; Russell, E. L. Miniaturized Total Analysis Systems for Biological Analysis. *Fresenius J. Anal. Chem.* **2000**, *366*, 525–539.
- (31) Attiya, S.; Jemere, A.; Tang, T.; Fitzpatrick, G.; Seiler, K.; Chiem, N. Harrison, D. J. Design of an Interface to Allow Microfluidic Chips to Drink from the Fire Hose of an External Environment. *Electrophoresis* **2001**, *22*, 318–327.
- (32) Lacher, N.; Garrison, K.; Martin, R. S.; Lunte, S. M. Microchip Capillary Electrophoresis/Electrochemistry. *Electrophoresis* **2001**, *22*, 2526–2536.
- (33) Wang, J. Electrochemical Detection for Microscale Analytical Systems: A Review. *Talanta* **2002**, in press.
- (34) Wang, J.; Tian, B.; Sahlin, E. Micromachined Electrophoresis with Thick-Film Electrochemical Detectors. *Anal. Chem.* **1999**, *71*, 5436–5440.
- (35) Wang, J.; Chatrathi M. P.; Tian, B. Microseparation Chips for Performing Multienzymatic Dehydrogenase/Oxidase Assays: Simultaneous Measurement of Ethanol and Glucose. *Anal. Chem.* **2001**, *73*, 1296–1300.

AR010066E